



GH 5050

FEATURES

- Five year limited warranty.
- Forged brass manifold with an exclusive lifetime warranty.
- Large capacity, die-cast, anodized aluminum oil-bath crankcase.
- Over-sized connecting rods and crankshaft for maximum life.
- Heavy-duty tapered roller bearings.
- Solid ceramic plungers with mirror finish and corrosion resistance.
- Parker "U" seals for premium performance.
- Stainless steel inlet and discharge valve assemblies.
- Machined stainless steel valve caps with recessed O-rings to withstand high pressures.
- Dacromet[®] coated manifold bolts for superior corrosion resistance.



SPECIFICATIONS

PUMP MODEL	GH 5050
Maximum Volume (GPM)	5
Max. Discharge Pressure (PSI)	5000
Maximum Pump Speed	1650
Maximum Inlet Pressure	125 psi
Maximum Inlet Vacuum	9 ft. water (7.9 in. Hg)
Bore	18mm
Stroke	17mm
Crankcase Oil Capacity	40 oz.
Maximum Fluid Temperature	165° F
Inlet Port Thread	1/2" BSP
Discharge Port Thread	3/8" BSP
Shaft Diameter x Shaft Length	25mm x 55mm
Weight	39 lbs
Dimensions (L x W x H)	12.85 x 10.23 x 6.45

LEGACY PUMPS • USA

Phone: 1-360-833-1600 Fax 1-360-833-9200

#8.915-926.0 • Rev. 5/07



GH 5050 Pump

5-1940 GH5050 Left
5-1941 GH5050 Right

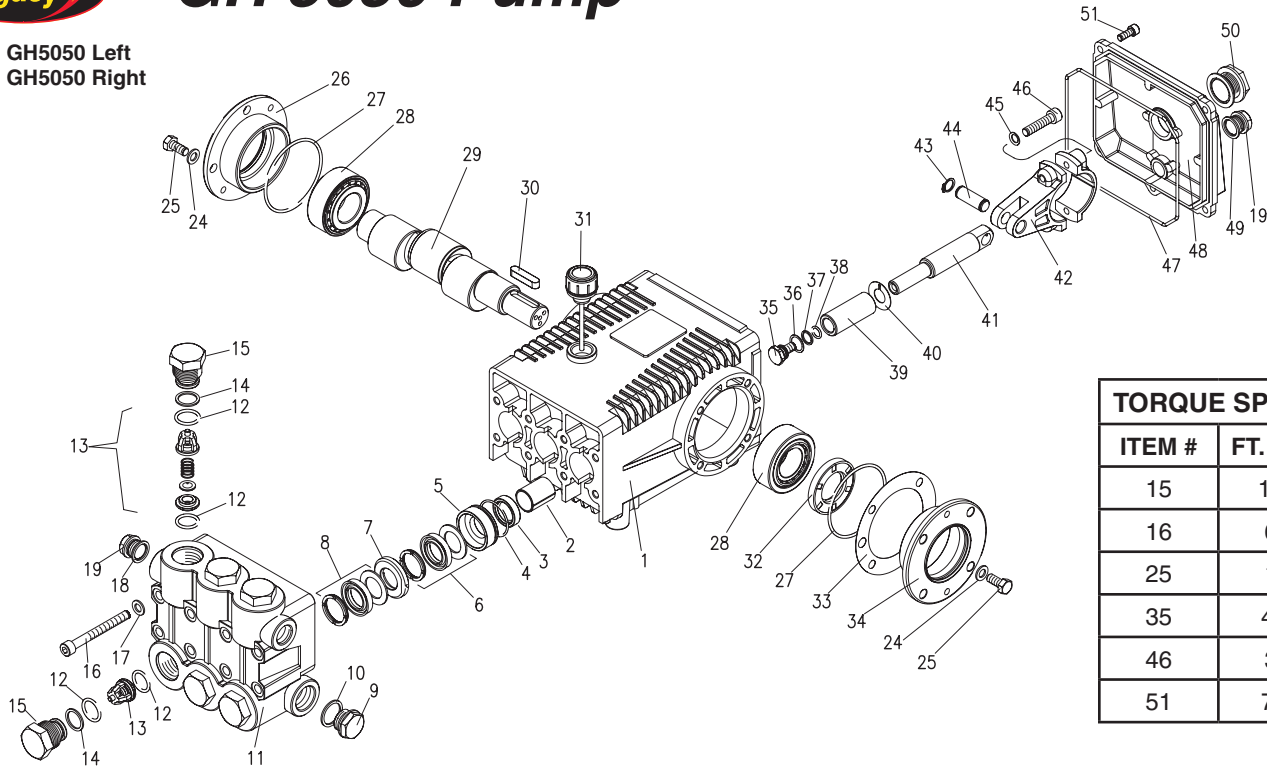

TORQUE SPECS	
ITEM #	FT. LBS.
15	135
16	60
25	18
35	4.5
46	30
51	7.6

PARTS LIST

ITEM	PART NO.	DESCRIPTION	QTY	ITEM	PART NO.	DESCRIPTION	QTY	ITEM	PART NO.	DESCRIPTION	QTY
1	70-020210	Crankcase	1	17	70-140301	Lock Washer	8	37*	70-060103	O-Ring Ø1.78x7.66	3
2	70-060200	Plunger Guide	3	18	70-060306	Copper Washer 3/8	1	38*	70-000904	Teflon Ring	3
3*	See Kit Below	Plunger Oil Seal	3	19	70-160117	Brass Plug 3/8	2	39*	Kit 70-261217	Plunger 18mm	3
4*	See Kits Below	O-Ring Ø1.78 x 37.82	3	24	70-140001	Washer	8	40*	70-140015	Copper Spacer	3
5*	See Kits Below	Pressure Ring 18mm	3	25	70-180203	Hex Screw	8	41	70-000310	Plunger Rod	3
6*	See Kit Below	U Seal, Dia. 18 x 28mm	3	26	70-050058	Closed Bearing Housing	1	42	70-010000	Connecting Rod	3
7*	See Kits Below	Support Ring 18mm	3	27	70-060100	O-Ring Ø2.62 x 71.12	2	43	70-150000	Snap Ring	6
8*	See Kits Below	U Seal, Dia 18 x 28mm	3	28	70-020005	Roller Bearing	2	44	70-150200	Connecting Rod Pin	3
9	70-160120	Brass Plug, 3/4	1	29	70-000474	Crankshaft	1	45	70-140103	Spring Washer	6
10	70-060307	Copper Washer 3/4	1	30	70-020605	Crankshaft Key	1	46	70-180101	Connecting Rod Screw	6
11	70-160210	Manifold Housing	1	31	70-160007	Oil Dip Stick	1	47	70-060185	O-Ring Ø2.62 x 152.07	1
12*	70-060105	O-Ring Ø2.62 x 23.47	6	32	70-000100	Crankshaft Seal	1	48	70-020351	Crankcase Cover	1
13*	See Kit Below	Valve Assembly	6	33	70-030100	Shim	2	49	70-060302	Gasket, G3/8	1
14*	70-000910	Teflon Ring	6	34	70-050057	Bearing Housing	1	50	70-070005	Sight Glass G3/4	1
15	70-160110	Valve Plug	6	35*	70-180001	Plunger Bolt	3	51	70-180112	Cover Screw	5
16	70-180133	Manifold Stud Bolt	8	36*	70-140012	Copper Spacer	3				

* Available in kit (See below)

REPAIR KITS

KIT NUMBERS	70-260220	70-260221	70-261217	70-260018	70-260023
KIT DESCRIPTION	Plunger Seal 18 mm	Seal Packing 18 mm	Plunger 18 mm	Complete Valve	Plunger Oil Seals
ITEMS NUMBERS INCLUDED	4, 6, 8	3, 4, 5, 6, 7, 8	35, 36, 37, 38, 39, 40	12, 13, 14	3
NUMBER OF CYLINDERS KIT WILL SERVICE	3	1	1	6	3